

SPLICE/VALVE BOX FC1730WUC

Applications:

Sidewalk, driveway and parking lot areas for telephony, power, CATV, DOT, water utility and other applications.

Features & Benefits:

- ◆ Lightweight and high-strength FRP and Polymer Concrete provide long life and quick and easy installation.
- ◆ Full line of configurations are available from stock to meet your load and depth requirements.
- ◆ Non-metallic, non-conductive materials eliminate grounding requirements.
- ◆ Sunlight resistant for long life over a wide range of temperature extremes.
- ◆ Excellent resistance to fertilizers and other chemicals.
- ◆ Larger "clear" opening maximizes work area, perfect for large valve applications.
- ◆ Interlock for concrete sidewalk retention and/or lift handle prevents tilting or frost heaving.

Options:

- ◆ EMS marker for quick and easy identification.
- ◆ OEM labeling (cast-in identification).
- ◆ Gaskets, cable racks, strut inserts, and terminators.
- ◆ Customizing services - knockouts, bolt and conduit holes.

Ordering Information:

Specify part numbers listed in the table below. Special configurations available. Consult factory for more information.

Pallet Quantity: 10

| Part No. | Description | Material | Weight |
|--------------|--------------------------|----------|---------|
| FCB173018C02 | Box, 18", Tapered - 10K | FRP | 69 (31) |
| FCE173008C02 | Extension, 8" | FRP | 33 (15) |
| FCE173016C02 | Extension, 16" | FRP | 53 (24) |
| CMC173000A02 | Cover, 2 bolt - CM - 10K | CM | 50 (23) |
| CMC173000A04 | Cover, 2 bolt - CM - 20K | CM | 50 (23) |
| STC173000A04 | Cover, 2 bolt - 20K | Steel* | 74 (34) |

* See STEEL COVER OPTIONS (page 45).

Sidewalk Application **SW**
Driveway/Parking Lot Application **DP**
Load: See table below

Stainless steel hex head bolts are standard on bolt down covers. Boltless covers are also available. Consult factory.

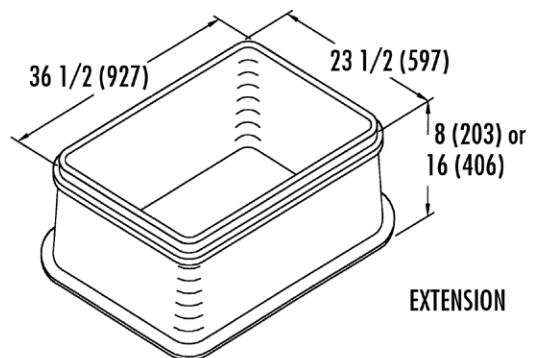
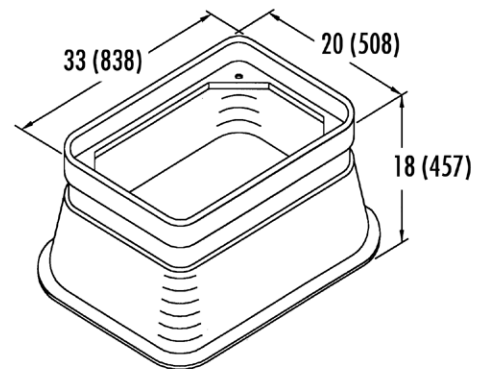
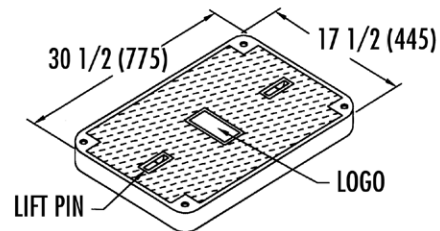

Dimensions: Inches (mm)
Weight: lbs (kg)